



EMV – Banking and Retail

NBX – A&L Application Interface Specification (AIS)

ROLE	NAME	AREA OF RESPONSIBILITY	SIGNATURE	DATE
Authors	Rex Dixon on behalf of Post Office Ltd	Business Architecture		
		Product Deployment		
		Technical Architecture		
DA Sign-off (Peer Reviewer)	David Gray	Design Authority		
Programme Director	Beverley Dunn	Project Delivery		
Alliance & Leicester Sign-off	Ian Antrobus			
Fujitsu Services Sign-off	Gill Jackson			

**NBX – A&L Application
Interface Specification**

Project:

EMV – Banking and Retail

Doc Ref:

NB/IFS/026

COMMERCIAL IN CONFIDENCE

1 Document Control

1.1 Document Information

Horizon Release No:	S75
Document Title:	EMV Banking and Retail: NBX – A&L Application Interface Specification
Document Type:	Application Interface Specification
Abstract:	This document details the application interface between the Horizon domain and Alliance and Leicester, including the interface to the ICC
Document Status:	Approved
Originator & Department:	David Gray Design Authority
Contributors:	
Post Office Distribution:	Design Authority – David Gray POL Document Control – Post Office Programme Office
Supplier Distribution:	A&L: Mark Clarke Fujitsu Services: Gill Jackson
Client Distribution:	N/A

Table 1: Document Information

1.2 Document History

Version	Date	Reason for Issue	Associated WP / CT
0.1	8 Dec 2003	First working draft. Based on document produced by IBM entitled "NBE – Alliance and Leicester AIS version 2.0 dated 10/01/2003	
0.2	28 Jan 2004	Second working draft. Based on NBX-LINK AIS version 0.5 as agreed with A&L at meeting 21/01/2004	
0.3	12 Feb 2004	Updated following joint review on 11 Feb 2004	
0.4	4 Mar 2004	Updated following responses from A&L	
0.5	7 Apr 2004	Updated following teleconference 17/03 and subsequent clarifications	
1.0	12 May 2004	Updated following meeting 28/4/04 and teleconference 12/05/04	
1.1	16 Aug 2004	Updated with latest agreed changes	

**NBX – A&L Application
Interface Specification**

Project:

EMV – Banking and Retail

Doc Ref:

NB/IFS/026

COMMERCIAL IN CONFIDENCE

1.2	22 Sep 2004	Updated following formal review	
2.0	17 Sep 2004	Issued for Sign-off (based on version 1.1)	
3.0	5 Oct 2004	Issued for Sign-off (based on version 1.2 apart from two names)	
3.1	26 May 2005	Updated for minor corrections discovered during testing prior to initial release at Horizon release S75	
3.2	4 Aug 2005	Minor changes as a result of review: some names removed, copyright statement updated	
4.0	15 Aug 2005	Issued for Sign-off	

Table 2: Document History

1.3 Change Process

Any changes to this issued version of this document will be made, controlled and distributed by: -

Elaine Hollingworth-Clarke GRO

1.4 Review Details

Review Comments by :	
Review Comments to :	Rex Dixon, Fujitsu Services

Mandatory Review Authority	Name
Post Office Ltd	Beverley Dunn, David Gray
Fujitsu Services Ltd	
Analysis & Solution Specification	Allan Hodgkinson
DU Design Authority	Andy Kennedy
DU Design Team Designer	Rex Dixon
Test Design	Peter J. Robinson
Alliance and Leicester	Mark Clarke, Steve Green, Neil Scott
Optional Review / Issued for Information	
Post Office Ltd	Bob Booth, Marc Reardon, Jason Crellin
Fujitsu Services Ltd	
Release Manager	Bill Reynolds
DU Design	Mark Jarosz, Alex Robinson
DU Development Team Leader	Peter Ambrose
Alliance and Leicester	

**NBX – A&L Application
Interface Specification**

Project:

EMV – Banking and Retail

Doc Ref:

NB/IFS/026

COMMERCIAL IN CONFIDENCE

1.5 Changes in this Version

Version	Changes
4.0	Gill Jackson added as signatory for Fujitsu Services
3.2	Removed certain reviewer names as requested.
3.1	<p>Sections 4.1.2, 4.2.1.2, 4.2.2.2, 4.2.3.2, 4.2.4.2, 4.2.5.2 and 4.2.6.2 – Application PAN Sequence Number (bitmap ref. 023): clarified that it is required for manually entered transactions only when the card's issue number has been captured. [FS Peak 110188, 110679]</p> <p>Sections 4.1.2 and 4.2.1.2 – Authorisation Data (bitmap ref. 123): removed from 0100 message. [POL Incident 1153; FS Peak 108959]</p> <p>Section 4.1.2 – Point of Service Data (bitmap ref. 061), subfield 2 (Cardholder authentication capability): added value 0 (No electronic authentication) for deposits. [POL Incident 1212; FS Peak 110150]</p> <p>Section 4.2.4.2 (Balance Enquiry Response) – Clarified that, for a decline, the length of this field must be set to '000'. [POL Incident 1196]</p> <p>Section 4.2.7.2 (Reversal Request) – Added a note that NBX does not include any of the Optional fields.</p>

Table 3: Changes in this Version

1.6 Key Contacts

Name	Position	Phone Number
Jason Crellin	Solutions Architect, Post Office Ltd	GRO
Mark Clarke	Senior Manager, Retail Bank, A&L	
Rex Dixon	Design, Fujitsu Services	

Table 4: Key Contacts

1.7 Associated Documents

**NBX – A&L Application
Interface Specification**

Project:

EMV – Banking and Retail

Doc Ref:

NB/IFS/026

COMMERCIAL IN CONFIDENCE

	Reference	Version	Date	Title	Source
1.	NB/IFS/029			NBX – A&L Technical Interface Specification	Post Office
2.	NB/OLA/003			Horizon – A&L Operational Level Agreement	
3.	NB/IFS/030			NBX – FI Reconciliation and Settlement File Format AIS	
4.	LIS5	2004-1 Vsn 1.1		LINK Switch Service Interchange Standard (LIS5)	LINK
5.	SU/PLA/016	0.3		NB Volume Model Comparisons	Post Office
6.	NB/IFS/034			NBX – A&L Mapping	Post Office
7.		1.2		LIS5 – Deposits “What’s New”	LINK
8.		Vsn 5.6	Jan 2002	LINK Switch Service Interchange Standard (LIS5 Security Standard)	LINK

Table 5: Associated Documents

Unless a specific version is referred to above, reference should be made to the current approved versions of the documents.



Table of Contents

1	DOCUMENT CONTROL	2
1.1	Document Information	2
1.2	Document History	2
1.3	Change Process	3
1.4	Review Details	3
1.5	Changes in this Version	4
1.6	Key Contacts	4
1.7	Associated Documents	5
2	INTRODUCTION	8
2.1	Purpose	8
2.2	Scope	8
2.3	Structure	8
2.4	Terms and Abbreviations	8
3	OVERVIEW OF THE INTERFACE	9
3.1	Data Description	9
3.2	Derivation and Use of Data	11
3.3	Non Computer Data	13
4	DATA ITEMS	14
4.1	Data Item List	14
4.1.1	General Message Element Definitions and Abbreviations	14
4.1.2	Messages Data Elements	16
4.2	Data Interpretations	27
4.2.1	[R3] - Balance Enquiry	28
4.2.2	[R3] - Financial Transaction Request - Withdrawal	29
4.2.3	[R3] - Financial Transaction Request - Deposit	31
4.2.4	[A1] - Balance Enquiry Response	33
4.2.5	[A1] - Financial Transaction Request Response - Withdrawal	34
4.2.6	[A1] - Financial Transaction Request Response - Deposit	35
4.2.7	[E1] - Reversal Request	36
4.2.8	[E2] - Reversal Request Response	38
4.2.9	Administration Advice (0620)	39
4.2.10	Network Management Messages (0800 / 0810)	40
4.2.11	Reconciliation and Settlement	41

**NBX – A&L Application
Interface Specification**

Project:

EMV – Banking and Retail

Doc Ref:

NB/IFS/026

COMMERCIAL IN CONFIDENCE

5	TRANSFER STRUCTURE	42
5.1	Transfer Grouping	42
5.2	Transfer Structure	42
5.3	Record Structure	43
5.4	Sequences	43
5.5	Data Volumes	43
5.6	Data Authentication	43
5.7	Data Dictionary	43
6	SECURITY OF TRANSMITTED DATA	44
6.1	Protected Data	44
6.2	Encryption and Decryption Methods	44
6.3	Session Establishment	44
6.4	Key Management	44
7	OPERATIONAL PROCEDURES	46
7.1	Processing Cycles	46
7.2	Transfer Initiation	46
7.3	Security Procedures	46
7.4	Fallback Procedures	46
7.5	Downgrade Transactions	47
7.6	Control	47
8	APPENDIX A	48



2 Introduction

2.1 Purpose

The purpose of this document is:

1. To specify the interface between the NBX and Alliance & Leicester (A&L) using the LINK [LIS5] standard as the basis for development (Ref. [4]).
2. To provide the development teams with sufficient detail to develop the NBX - A&L interface.
3. To provide a consistent communications vehicle amongst the development teams that have responsibility for developing the various components comprising the application.

2.2 Scope

This document applies to the interface between the NBX and A&L only. It includes only those financial transaction messages and network messages sufficient to support the financial products being delivered by Post Office Limited via the A&L systems.

This AIS is concerned only with the application messages exchanged over the interface between NBX and A&L. The technical interface between the NBX and A&L will be specified in a Technical Interface Specification (Ref. [1]). There are a number of other key points, which must be borne in mind when reading this document:

1. Alliance and Leicester use the BASE24 system to support its card-based ATM transactions.
2. The BASE24 system in conjunction with the NBX will base this interface on the LINK Switch Service Interchange Standard (Ref. [4])
3. The A&L interface does not support PIN change or "Withdraw Limit" transactions.

2.3 Structure

Section 3 contains a high level overview of the NBX – A&L interface and its context.

Section 4 contains a detailed description of the messages to be exchanged, and the derivation and use of the exchanged data items. All data items exchanged are specified in LINK Switch Service Interchange Standard (LIS5) documentation (Ref. [4]).

Section 5 contains details of the data transfer.

Section 6 contains details of security of the exchanged data items. This section identifies the security needed for each data item (e.g. encryption) and details of the method to be used.

Section 7 contains any relevant details of operational procedures relating to the interface.

2.4 Terms and Abbreviations

No Entries

**NBX – A&L Application
Interface Specification**

Project:

EMV – Banking and Retail

Doc Ref:

NB/IFS/026

COMMERCIAL IN CONFIDENCE

3 Overview of the Interface

3.1 Data Description

The following messages are exchanged over the NBX - A&L interface:

NBX Message Id	Description	Direction
[R3]	Authorisation / Financial Transaction Request: <ul style="list-style-type: none"> balance enquiry (0100) withdrawal (0200) deposit (0200) Note that there is no separate message to A&L for withdrawal with balance. A&L control the return of balance information.	NBX -> A&L
[A1]	Authorisation / Financial Transaction Request Response: <ul style="list-style-type: none"> balance enquiry response (0110) withdrawal response (0210) deposit response (0210) Each of the above will have a response code that indicates approve or decline with reason and any required action (e.g. card retention).	A&L -> NBX
[E1]	Reversal Request: <ul style="list-style-type: none"> Acquirer Reversal Advice (0420) Acquirer Reversal Advice Repeat (0421) The NBX has a configurable maximum number of retries for this message of 9999, although this is usually set to between 3 and 5. The message is then logged as undeliverable and will require a manually entered command to remove the rogue message from the store and forward queue.	NBX -> A&L
[E2]	Reversal Advice Response (0430)	A&L -> NBX
0620	Administration Advice (0620) Administration Advice messages (0620) are sent to/from NBX in order to initiate investigation of a problem by either A&L or Post Office Ltd	NBX -> A&L OR A&L -> NBX



**NBX – A&L Application
Interface Specification**

Project:

EMV – Banking and Retail

Doc Ref:

NB/IFS/026

COMMERCIAL IN CONFIDENCE

0800	<p>Network/Key Management Request (0800):</p> <ul style="list-style-type: none"> • Handshake (Echo test) • Logon / Logoff (Sign on / Sign off) • End of Day (Cutover) • Key Change • Key Change Request <p>Note A&L do not support Online Verification</p> <p>At end of day, NBX to act as master and send 0800 to A&L. NBX must keep sending this until End of Day response message 0810 received from A&L.</p>	<p>NBX -> A&L A&L -> NBX</p> <p>Actual flows are documented in section 4.2.10.</p>
0810	Network/Key Management Request Response (0810)	<p>A&L -> NBX NBX -> A&L</p>
Reconciliation and Settlement	<p>A Reconciliation file is sent at end of day by NBX to A&L. This provides a record for all A&L transactions for settlement day, for which the NBX has [R3] and [A1] messages and totals of all financial transactions for that settlement day. (A&L will need to compare this file against their daily transactions to agree transactions for the day. The method of reconciliation of settlement differences between A&L and Post Office is outside the scope of this document.</p> <p>A&L will ONLY reconcile and settle based on the Reconciliation File Format – (Ref. [3]).</p>	NBX -> A&L



3.2 Derivation and Use of Data

The messages listed above are generally exchanged as a result of a transaction initiated either by a clerk at a Post Office outlet or by A&L. The NBX acts as a message router, filtering messages based on business rules and transforming received messages into the appropriate format for forwarding to the next system in the message sequence.

The following table shows the derivation and use of each banking transaction message exchanged between the NBX and A&L in terms of the received message that causes each NBX - A&L message to be exchanged, and the transmitted message resulting from the NBX - A&L message exchange. The shaded columns indicate the systems and connecting interface addressed by this AIS.

Message Sequence						
Horizon Outlet		Horizon Campus		NBX		A&L
	[R1] →		[R2] →		0100/0200 [R3] →	
	← [A3]		← [A2]		0110/0210 ← [A1]	
[C0] →			[C2] →		0420/0421 [E1] →	
					0430 ← [E2]	

The messages exchanged over this interface relating to end of day, reconciliation and settlement are initiated by NBX, and are neither derived from received messages nor used to generate onward messages.

Security key exchange messages are initiated by A&L and acknowledged by NBX. The business processes with respect to these messages are addressed in the Operational Procedures Manual, (Ref.[2]). The following table shows the derivation and use of each security message exchanged between A&L and the NBX.



NBX – A&L Application Interface Specification

Project: EMV – Banking and Retail
Doc Ref: NB/IFS/026

COMMERCIAL IN CONFIDENCE

Message Sequence						
Horizon Outlet		Horizon Campus		NBX		A&L
					←	0800 (Logon 061)
				0810	→	
					←	0800 (Key Change - Acquirer zone code 161)
				0810	→	
				0800 (Logon 071)	→	
					←	0810
					←	0800 (Key Change - Acquirer zone code 161)
				0810	→	
					←	0800 (Key Change - Acquirer zone code 161)
				0810	→	
				0800 (Key Change Request - Acquirer zone 181)	→	
					←	0810
					←	0800 (Key Change - Acquirer zone code 161)
				0810	→	

If NBX requires a working key change it sends an 0800 Change Key Request message to A&L. A&L sends an 0810 response to the Change Key Request message followed by an 0800 Key Change message containing the new working key. A&L may initiate a change of working key by sending an 0800 Key Change message.

Either the NBX or A&L can log on. The table above shows the sequence of events when either of these happen. A&L will send a Key Change message when it has received a Logon response from the NBX or once it has sent the Logon response to a Logon message received from the NBX. If the NBX does not receive the Key Change message within a reasonable period (10 seconds), it will send a Key Change Request message to A&L. Upon receipt of this message, A&L can either initiate the key change or reject it with a response code indicating key exchange in progress.

Other 0800 messages may be initiated by either A&L or NBX (with the exception of the 0800/261 End of Day (Cutover) message, which is NBX-initiated), and are acknowledged by an 0810 response from the other side.

The use of Handshakes is described in the NBX – A&L Technical Interface Specification (Ref. [1]),

All 0100 and 0200 messages generated by NBX prior to NBX sending the 0810 approved Key Change response will have used the current AWK to encrypt the PIN Block. As soon as the 0810 approved Key



**NBX – A&L Application
Interface Specification**

Project: EMV – Banking and Retail

Doc Ref: NB/IFS/026

COMMERCIAL IN CONFIDENCE

Change response is transmitted, the new AWK becomes active at NBX so that all messages generated after it use the new AWK to encrypt the PIN Block.

In the event that the Key Check Value received by NBX (with the AWK in the 0800/161 Key Change message) does not match the one created when testing the new AWK, NBX will return an 0810 denied response. Under these circumstances the new AWK will NOT be implemented and any subsequent transactions will continue to have the PIN Block encrypted using the current AWK.

In order to prevent race conditions, NBX will not accept a new AWK if the previous AWK was established less than a configurable period earlier (e.g. 1 minute) within a session.

A&L sets a flag during key change that is cleared when the key change is concluded.

3.3 Non Computer Data

All data being transported across this interface is originated/received from a connected computer system or from reference data (supplied by the Post Office Limited RDS or held internally within the NBX).

4 Data Items

4.1 Data Item List

4.1.1 General Message Element Definitions and Abbreviations

The following section summarises the list of Message Elements for each group of transactions, together with which message(s) they are present in. Each message is classified and identified using the RAC (Request / Authorise / Confirm) model. Each message element references the corresponding LIS5 Standard bitmap position (Ref. [4]).

The abbreviations used to describe the format of each data element (DE) and Data Sub-elements are shown in the following table:

Notation	Explanation
a	Alphabetic characters only (upper case)
n	Numeric Digits only
s	Special characters
an	Alphabetic or Numeric characters (upper case)
as	Alphabetic or Special characters (upper case)
ns	Numeric or Special characters
ans	Alphabetic, Numeric or Special characters only (upper case)
DD	Day
MM	Month
YY	Year
hh	Hour
mm	Minutes
ss	Seconds
LL	Length of variable field that follows represented using two characters
LLL	Length of variable field that follows represented using three characters
VAR	Variable length field
3	Fixed length field (e.g. 3 characters in this example)
.. 10	Variable length field (e.g. up to a maximum of 10 characters in this example). LL or LLL to indicate the actual length of the field will prefix all variable length fields. Where the field length has been specifically defined this has been included.
h	Hexadecimal representation of the data
z	Tracks 2 and 3 data, as defined by ISO 7811 and ISO 7813

The Field Size column gives the number of characters (octets) required for the data item, as shown in the table below.

Abbreviation	Description
3	Fixed Length field. Numeric fixed length fields are right justified and zero padded. Fixed length string fields are left justified and space padded.
.. 10	Variable length field (up to a maximum of 10 characters in this example).

The Source column indicates the system or user originating the data.

The "Description" column contains a brief description of the field, as used in the messages defined in this AIS together with any additional comments.

The "Required" column indicates whether the field is Mandatory or Conditional for the messages defined in this AIS. For conditional fields, the field description should indicate under what circumstances the data for the field should be populated or omitted from the message.

**NBX – A&L Application
Interface Specification**
Project: EMV – Banking and Retail

Doc Ref: NB/IFS/026

COMMERCIAL IN CONFIDENCE

Code	Meaning
M	<p>The element is mandatory for this message. On messages sent to BASE24, if a mandatory element is not present in a message, the message is rejected and returned to NBX.</p> <p>On messages sent by BASE24, a mandatory data element is always present. If BASE24 does not have the appropriate information for the element, BASE24 fills the field with zeros or spaces or sets the length indicator to zero.</p>
C	<p>The element is conditional for this message, and the condition to be applied is stated in the Conditions column. It should be noted that the receiving system may not be able to assess whether the condition has been met, in which case it must be able to interpret the presence or non-presence of the element according to appropriate business rules.</p> <p>On messages sent to BASE24, a conditional data element must be present if BASE24 requires the conditional element for processing. If it is not present, the message is rejected and returned to NBX.</p> <p>On messages sent by BASE24, a conditional element is only included if it is required for the particular type of message being sent. If the element contains spaces, it is not sent. If the element contains data and the data is valid, BASE24 includes the element in the message.</p>
O	Optional - See Message Definitions for rules

Notes:

- Fixed length numeric fields are unpacked, right justified and zero filled.
- Fixed length alphanumeric fields are left justified and space filled.
- All messages between the NBX and A&L will be encoded in ASCII format (English character set, CCSID = 437),

4.1.2 Messages Data Elements

The Data Elements exchanged within messages over this interface are listed below. The Primary Bit Map data element is mandatory in every LIS5 message and is not shown. The Secondary Bit Map is required if any of data elements 65 through 128 are included in the message, otherwise it is not used. The Tertiary Bit Map is required if any of data elements 129 through 192 are included in the message (e.g. ICC fields).

In the following table, rows/columns are sometimes shaded in grey. This indicates that the field is not required and may not be populated in messages from NBX to A&L. The NBX will log any such fields received from A&L but will not process them further.

A&L Data Elements	Bitmap Ref.	Format	Field Size	Source	Notes	Required								
						[R3] 0100	[R3] 0200	[A1] 0110	[A1] 0210	[E1] 0420 /0421	[E2] 0430	0620	0800	0810
Account Identification 1	102	ans LLVAR	.. 28	Issuer	NBX does not pass Account Identification 1 field to the counter systems [For a withdrawal, holds the account number from which the funds are withdrawn; for a balance enquiry it is the account number for which the balances are provided. It is not used for a deposit transaction.]			M	M	M				
Acquiring Institution Country Code	019	n	3		Not appropriate to messages passed on this interface									
Acquiring Institution Identification Code	032	n LLVAR	.. 11	NBX from Ref Data	Code identifying the Acquirer (Post Office Limited). Set to 2200040000 preceded by a length indicator of 10.	M	M	M	M	M	M			
Additional Amounts	054	an LLLVAR	.. 120	Bank	Identifies account balance value (included if provided by bank)			M	C					



**NBX – A&L Application
Interface Specification**

Project: EMV – Banking and Retail

Doc Ref: NB/IFS/026

COMMERCIAL IN CONFIDENCE

Additional Response Data	044	ans LLVAR	.. 25	Bank	<p>Not appropriate to messages passed on this interface.</p> <p>[On original interface, this was used for incoming 0210 messages, this element is used for account balance information on withdrawals as well as balance enquiries. Maximum of 2 balances passed: Ledger Balance, Available Balance (includes, Shadow Balance, Remaining Overdraft Balance etc.). It is the total Available Balance on the account; not the daily card limit for the card, less any previously withdrawn amount for the day.</p> <p>The format of the field:</p> <p>Digit 1-2 = 25 (field length indicator LL)</p> <p>Digit 3 set to:</p> <p>1 = Ledger balance present only 2 = Available balance present only 3 = Both balances present; use ledger balance if only one can be used 4 = Both balances present; use available balance if only one can be used</p> <p>When digit 3 is set to 3 or 4 then the NBX will always send both balances to Horizon if both are present, including zero balances..</p> <p>Digits 04–15 Ledger Balance Digits 16–27 Available Balance.</p> <p>If a negative amount is to be expressed, the leftmost byte will contain a minus sign (-); otherwise, it will contain a zero.]</p>									
--------------------------	-----	--------------	-------	------	--	--	--	--	--	--	--	--	--	--



**NBX – A&L Application
Interface Specification**

Project: EMV – Banking and Retail
Doc Ref: NB/IFS/026

COMMERCIAL IN CONFIDENCE

Advice / Reversal Reason Code	060	an LLLVAR	..9	NBX	Used in NBX interface for advice, reversal and ICC transactions. Required for advice, reversal and ICC transactions. Used in request messages from ICC capable terminals to indicate Status of Last Chip Read attempted and to provide Cryptogram Information Data Magnetic stripe cards <i>Reversal Requests (0420/0421 messages):</i> Bytes 1-2 are set to 80 Bytes 3-4 give a reason for the reversal. Remaining bytes are not transmitted ICC cards <i>[R3] Requests (0100/0200 messages):</i> Bytes 1-2 are set to 30 Byte 3 is Status of Last Chip Attempt Bytes 4-5 is Cryptogram Information Data <i>Fallback [R3] Requests (0100/0200 messages):</i> Bytes 1-2 are set to 30 Byte 3 is Status of Last Chip Attempt (value 2) Bytes 4-5 is Cryptogram Information Data (value C0) <i>Reversal Requests (0420/0421 messages):</i> Bytes 1-2 are set to B0 Bytes 3-4 give a reason for the reversal Byte 5 is Status of Last Chip Attempt Bytes 6-7 is Cryptogram Information Data See Appendix A for Reversal Reasons	C	C			M				
Amount, Cardholder Billing	006	n	12		Not appropriate to messages passed on this interface – foreign transactions not supported by NBX									
Amount, Transaction	004	n	12	Clerk at Outlet	Decimal amount in smallest unit of the specified currency (i.e. GBP pence or EUR cents) Not required for balance enquiry		M		M	M	M			
Amount, Transaction Fee	028	an	9		Post Office will not apply Acquirer charges (format annnnnnn)									
Amount, Transaction Processing Fee	030	an	9	Bank	Issuer charge (format annnnnnn). <i>Note : No fee data will be passed on the interchange.</i>				C					
Application Interchange Profile (AIP)	138	h	4	ICC	From ICC, indicating capability to support specific functions	C	C			O				



**NBX – A&L Application
Interface Specification**

Project: EMV – Banking and Retail

Doc Ref: NB/IFS/026

COMMERCIAL IN CONFIDENCE

Application PAN Sequence Number	023	n	3	Clerk at Outlet	Identifies and differentiates cards with the same PAN Required for ICC transactions, or if the card's issue number has been manually entered. Acquirer decision as to whether sent in the reversal message (0420/0421) – copied from original transaction. Required in 0430 if present in 0420/0421.	C	C	C	C	C	C				
Application Transaction Counter (ATC)	137	h	4	ICC	A sequence number (counter) calculated by the ICC and passed to the terminal application. Acquirer decision as to whether sent in the reversal message (0420/21) – copied from original transaction. Required in 0430 if present in 0420/0421.	C	C	C	C	O	C				
Authorisation Data	123	ans LLLVAR	.. 255	Clerk at Outlet	Sub-Fields 1-13, 15, 16 and 17 do not apply. Sub-Field 14 is used in PIN failure notification messages to inform bank of cause of script processing failure on ICC. Format of sub field is h .. 12 Sub-Field 18 Bilateral Discretionary Data must contain Start Date of card where one exists and the card details have been manually entered. Format of Sub-Field 18 is: ans ..99		C			C					
Authorisation Identification Response	038	an	6	Bank	Not required for NBX transactions - POS Transactions Only										
Authorisation Response Data	121	ans LLLVAR	.. 255		Not required for NBX transactions - used for Cheque Clearance Date. This could be returned by an issuer to state when cheque funds will clear. NBX must be able to accept this, but will log only.										
Authorising Agent Institution Id Code	113	n LLLVAR	.. 11	Bank	Institution approving or declining the transaction			M	M						
Bit Map Secondary	001	h	16	NBX from system	Indicates presence of data elements in a message in range 065 to 128. This data element may be omitted if no elements in range 065 to 128 are contained in message	C	C	M	M	M	M	M	M	M	M
Bit Map Tertiary	065	h	16	NBX from system	Required for ICC based transactions (i.e. data elements in range 129 to 192)	C	C	C	C	C	C				
Card Acceptor Identification Code	042	ans	15	NBX from system	NBX will populate with the Post Office short name from reference data, left justified and space filled		M			M					



**NBX – A&L Application
Interface Specification**

Project: EMV – Banking and Retail

Doc Ref: NB/IFS/026

COMMERCIAL IN CONFIDENCE

Card Acceptor Name / Location	043	ans	40	NBX from Ref Data	First 40 characters of outlet address in format: 01-23 first 23 chars of Name and Address (= first 23 chars of ADDRESS 1 from POL RDS) 24-38 first 15 chars of City (= first 15 chars of ADDRESS 4 from POL RDS) 39-40 GB This field may be sent in mixed case to A&L by the NBX (except GB, which must be in upper case)	M	M			M					
Card Acceptor Terminal Identification	041	ans	8	Outlet from system	Comprises 6 digit outlet id (group_id) + 2 digit terminal id (node_id)	M	M	M	M	M					
Conversion Rate, Cardholder Billing	010	n	8		Not required - foreign currency transactions are not supported by NBX.										
Cryptogram (ARQC)	136	h	16	ICC	Computed by ICC for on-line application	C	C			O					
Cryptogram Amount	147	n	12	ICC	Transaction amount used by ICC in generating cryptogram	C	C			O					
Cryptogram Currency Code	148	n	3	ICC	Contains transaction currency code used by ICC in generating cryptogram for an ICC transaction	C	C			O					
Cryptogram Transaction Type	144	n	2	ICC	Contains transaction type used by ICC in generating the cryptogram for an ICC transaction	C	C			O	O				
Currency Code, Cardholder Billing	051	an	3		Not required - foreign currency transactions are not supported by NBX										
Currency Code, Transaction	049	an	3	Clerk at outlet	Only 826 (GBP) will be accepted initially. NBX will translate GBP code received from Counters to 826 (using ISO 4217 standard) for A&L.	M	M	M	M	M	M				
Date, Expiration	014	YYMM	4	Clerk at Outlet	May be required where the card data is manually entered, determined by the reference data at the counter	C	C			C					
Date, Local Transaction	013	MMDD	4	Outlet from System	As printed on receipt, transaction request date in Local Time	M	M	M	M	M	M				
Date, Settlement	015	MMDD	4	NBX, then A&L	NBX sets in request to Acquirer's settlement date. A&L sets in response to A&L settlement date. The reversal message will contain the original, NBX set Settlement Date.	M	M	M	M	M	M				
File Name	101	ans	17		Not appropriate to messages passed on this interface.										
File Update Code	091	an	1		Not appropriate to messages passed on this interface.										



**NBX – A&L Application
Interface Specification**

Project: EMV – Banking and Retail

Doc Ref: NB/IFS/026

COMMERCIAL IN CONFIDENCE

Forwarding Institution Identification Code	033	n LLVAR	.. 11		Not required, since NBX is an Acquirer only													
Info Text	124	ans LLLVAR	.. 255	Sender	Contains up to the first 255 bytes of the message rejected by the sender (either NBX or A&L)													M
Issuer Application Data	134	h LLVAR	.. 64	ICC	Unique ICC related card data for card scheme	C	C			O								
Issuer Authentication Data	139	h LLVAR	.. 32	Issuer	A value computed by the Issuer to allow the ICC to authenticate the issuer returning the response. Comprises two sub-fields: <ul style="list-style-type: none"> ■ Sub-field 1 - ARPC (format h16) – must be included in a response where the ARQC has been verified successfully by the Issuer ■ Sub-field 2 - Optional Data (format .. h16) 			C	C									
Issuer Script	142	h LLLVAR	.. 255	Issuer	Contains commands for transmission to ICC from Issuer			O	O									
Issuer Trace Id	126	ans LLLVAR	6	Issuer	Issuer specified transaction identifier. Note: The field is FIXED length 6 but with the var field header ie LLLnnnnnn			M	M	M	M							
Merchant Type	018	n	4		Not required for NBX transactions - POS Transactions Only													
Message Authentication Code, Primary	064	h	16		Not currently supported over this interface													
Message Authentication Code, Secondary	128	h	16		Not appropriate to messages passed on this interface.													
Message Security Code	096	an	8	Sender	Password to network management requests (see Horizon – A&L OLA (Ref. [2])).													C
Network Management Information	125	ans LLLVAR	.. 60	Sender	Additional information required for key change and key verification: <ul style="list-style-type: none"> ■ Positions 01-32 - 32 byte working key ■ Positions 33-36 - check value (4 bytes) ■ Positions 37-38 - check value padding (zeroes) ■ Positions 39-60 - Spaces (optional) 													C



**NBX – A&L Application
Interface Specification**

Project: EMV – Banking and Retail

Doc Ref: NB/IFS/026

COMMERCIAL IN CONFIDENCE

Network Management Information Codes	070	n	3	A&L/ NBX	See Section 4.2.10 for values										M	M	M
Original Data Elements	090	n	42	NBX	Identifies an original transaction being reversed. 01-04 Original Transaction Type 0200 The remaining characters are zero filled.							M	M				
PIN Data	052	h	16	Outlet from customer	Customer PIN Entered by customer & encrypted using ISO 9564-1 Format 0 as defined in ANSI X9.8. Not supplied for verification by signature or deposit transactions (as no PIN authentication of the customer is undertaken)	C	C										
Point of Service Condition Code	025	n	2	Outlet	Initially to be set by NBX (from Ref Data) to 54 (Non ICC Capable Branch ATM). 55 will be used to indicate ICC Capable Branch ATM when chip read support added.	M	M					M					
Point of Service Data	061	ans	20	NBX	Subfield 1 will be set to: 8 – Mag. stripe & key entry (counter not ICC enabled) 9 – Mag. stripe, ICC & key entry (counter ICC enabled) Subfield 2 will be set to: 1 – PIN, 0 – No electronic authentication (<i>assumed for deposit</i>) Subfield 3 will be set to 1 – capture Subfield 4 will be set to 1 – On premises of card acceptor, attended, Subfields 5 and 6 will be set to 01 – Cardholder present, card present, Subfield 7 will be set to: 2 – Magnetic stripe, 5 – ICC, 6 – Manual Entry Subfield 8 will be set to 1 – PIN, 0 – No PIN (if deposit transaction) Subfield 9 will be set to 3 (Authorising agent = issuer) Subfield 10 = 1 (none) or 3 (ICC) Subfield 11 = 0 (unknown – mixed print & display capability, over time) Subfield 12 = C (pin capture length is up to 12 – h/w capability, usage is likely to be 4 digits only).	M	M					M					



**NBX – A&L Application
Interface Specification**

Project: EMV – Banking and Retail

Doc Ref: NB/IFS/026

COMMERCIAL IN CONFIDENCE

Point of Service Entry Mode	022	n	3	Outlet	Digits 1-2 will be: 01 (Manual entry) 05 (ICC) 90 (Mag Stripe, Track 2 read and fully transmitted, includes downgraded ICC cards) Digit 3 will be: 1 (PIN entry capability) 2 (No PIN entry capability) – used for deposit	M	M			M						
Point of Service PIN Capture Code	026	n	2		Not appropriate to messages passed on this interface - POS Transactions Only											
Primary Account Number	002	n LLVAR	.. 19	Outlet from card/Clerk at Outlet	Read from ICC for an ICC transaction, read from Track 2 data if card swiped, entered by the clerk when card details manually entered. [Identifies particular card, customer account or relationship]	M	M	M	M	M						
Processing Code	003	n	6	NBX	NBX will set digits 1 and 2 to 01 for Withdrawal 31 for Balance Enquiry 21 for cash deposit Digits 3 to 6 will be set to zero (default). All 6 digits passed by NBX and A&L.	M	M	M	M	M	M					
Replacement Amounts	095	an	42		Not required - partial reversals not supported by NBX [A&L - Not passed by NBX to BASE24. A transaction is either approved for the full amount requested or is declined (i.e. zero approved). A reversal will, therefore, be for the full amount requested (and not a part of it).]											
Response Code	039	an	2		Code indicating transaction step outcome. Source dependent on transaction type. The LIS5 Response codes will be used			M	M	M	M					M

¹ Systems Trace Audit Number [011] Time Local Transaction [012], Retrieval Reference Number [037] and Card Acceptor Terminal Identification [041] uniquely identify a transaction when combined.



**NBX – A&L Application
Interface Specification**

Project: EMV – Banking and Retail

Doc Ref: NB/IFS/026

COMMERCIAL IN CONFIDENCE

Retrieval Reference Number ¹	037	an	12	NBX	Additional transaction identifier, assigned by NBX. It MUST be unique for a terminal ID, at least within 1 business day. Additional transaction identifier, assigned by NBX, as follows: Digits 01-04 set to Julian date (YDDD) Digits 05-06 set to 00 Digits 07-12 set to a 6 digit cycling number generated at each counter	M	M	M	M	M	M			
Systems Trace Audit Number	011	n	6	NBX	Transaction identifier, assigned by NBX within the request, and included in all subsequent messages relating to that transaction ([A1] response and [E1] / [E2] reversal messages).	M	M	M	M	M	M	M	M	M
Terminal Capability Profile	130	h	6	Outlet	Required for ICC transactions - indicates card data input, CVM and security capabilities of terminal	C	C			O				
Terminal Country Code	145	n	3	Outlet	Country Code (ISO value) of terminal carrying out ICC transaction – value = 826	C	C			O				
Terminal Serial Number	133	an	8	Outlet	Unique and permanent identification number of chip terminal	O	O			O				
Terminal Transaction Date	146	n	6	Outlet	Contains transaction date in format YYMMDD used by ICC in generating the cryptogram for ICC transaction	C	C			O				
Terminal Verification Results (TVR)	131	h	10	Outlet	Status of different ICC functions as seen from terminal	C	C			O				
Time, Local Transaction	012	n	6	Outlet from System	As printed on receipt, transaction request time in Local Time in format hhmmss	M	M	M	M	M	M			
Track 2 Data	035	z LLVAR	.. 37	Outlet from card	Track 2 image.	C	C			C				
Transmission Date and Time	007	n	10	Sender	Date and time of transmission of the message (not carried forward from previous message). format MMDD hhmmss. The time base used in the message varies dependant on sender. NBX – sets as GMT (DST) A&L – Sets as UTC This data is therefore not carried forward from previous messages.	M	M	M	M	M	M	M	M	M
Unpredictable Number	132	h	8	Generated by terminal	Value providing variability and uniqueness to generation of the application cryptogram for an ICC transaction.	C	C			O				

¹ Systems Trace Audit Number [011] Time Local Transaction [012], Retrieval Reference Number [037] and Card Acceptor Terminal Identification [041] uniquely identify a transaction when combined.



**NBX – A&L Application
Interface Specification**

Project:

EMV – Banking and Retail

Doc Ref:

NB/IFS/026

COMMERCIAL IN CONFIDENCE

4.2 Data Interpretations

This section contains the definition of each message type to be sent over this interface. The Message Element column lists those elements required for the message according to LIS5, and relates to the list in Section 4.1. However, rows are sometimes shaded in grey. This indicates that the specific message will not include this data element in this interface.

The Required column in the message definition tables within this section contain the following codes:

Code	Meaning
M	The element is mandatory for this message
C	The element is conditional for this message, and the condition to be applied is stated in the Conditions column. If the condition is true, the element must be present in the message, otherwise the element must not be present in the message. It should be noted that the receiving system may not be able to assess whether the condition has been met, in which case it must be able to interpret the presence or non-presence of the element according to appropriate business rules.
O	Optional (see Message Definitions below for specific rules)

The Conditions column lists the conditions for inclusion of a conditional message element; inclusion of the element may depend on details of the transaction type, or simply whether the data is available to the sending system.

The message definitions given in the sections below do not include primary bitmaps. Primary, secondary and tertiary bitmaps will be used as required.

It is essential that developers of this interface also refer to the NBX A&L Mapping document, (Ref. [6]) for further details of data derivation and use.

Some fields on response messages from A&L are simply copies of fields from the request message. Where this is the case these fields are indicated with the text 'Echoed' in the Notes column. Where fields are copied from internal NBX fields to messages by the NBX these fields are indicated with the text 'Copied'.

**NBX – A&L Application
Interface Specification**
Project: EMV – Banking and Retail

Doc Ref: NB/IFS/026

COMMERCIAL IN CONFIDENCE

4.2.1 [R3] - Balance Enquiry

4.2.1.1 Overview

This message is sent by the NBX to A&L. The message requests a balance enquiry transaction.

The [R3] Balance Enquiry message maps to the following A&L message:

- 0100 - Balance Enquiry

4.2.1.2 Message Definition

Message Element	LIS5 Bitmap Reference	Required	Notes / Conditions
Bit Map Secondary	001	C	
Primary Account Number	002	M	
Processing Code	003	M	310000 for Balance Enquiry
Amount, Cardholder Billing	006		Not required
Transmission Date and Time	007	M	
Conversion Rate, Cardholder Billing	010		Not required
Systems Trace Audit Number	011	M	
Time, Local Transaction	012	M	
Date, Local Transaction	013	M	
Date, Expiration	014	C	Required for manually key entered balance enquiry transaction
Date, Settlement	015	M	Acquirer's settlement date
Point of Service Entry Mode	022	M	Please refer to section 4.1.2 for values
Application PAN Sequence Number	023	C	Required for ICC transactions, or if the card's issue number has been manually entered
Point of Service Condition Code	025	M	Please refer to section 4.1.2. for contents of the field
Acquiring Institution Identification Code	032	M	
Forwarding Institution Identification Code	033		Not required
Track 2 Data	035	C	Will not be present where card details manually entered.
Retrieval Reference Number	037	M	Please refer to section 4.1.2. for contents of the field
Card Acceptor Terminal Identification	041	M	
Card Acceptor Name / Location	043	M	
Currency Code, Transaction	049	M	
Currency Code, Cardholder Billing	051		Not required
PIN Data	052	C	Required if PIN used
Advice / Reversal Reason Code	060	C	Required for ICC transactions
Point of Service Data	061	M	Please refer to section 4.1.2 for values
Message Authentication Code	064		Not to be sent to A&L for this implementation.
Bit Map Tertiary	065	C	Required for ICC transactions
Terminal Capability Profile	130	C	Required for ICC transactions
Terminal Verification Results	131	C	Required for ICC transactions
Unpredictable Number	132	C	Required for ICC transactions
Terminal Serial Number	133	O	Optional for ICC transaction - to be inserted if available
Issuer Application Data	134	C	Required for ICC transactions
Cryptogram (ARQC)	136	C	Required for ICC transactions
Application Transaction Counter	137	C	Required for ICC transactions
Application Interchange Profile	138	C	Required for ICC transactions
Cryptogram Transaction Type	144	C	Required for ICC transactions
Terminal Country Code	145	C	Req'd for ICC transactions – see section 4.1.2 for value
Terminal Transaction Date	146	C	Required for ICC transactions
Cryptogram Amount	147	C	Required for ICC transactions
Cryptogram Currency Code	148	C	Required for ICC transactions
Message Authentication Code	192		Not required in this implementation

**NBX – A&L Application
Interface Specification**

Project:

EMV – Banking and Retail

Doc Ref:

NB/IFS/026

COMMERCIAL IN CONFIDENCE

4.2.2 [R3] - Financial Transaction Request - Withdrawal

4.2.2.1 Overview

This message is sent by the NBX to A&L. The message requests a withdrawal transaction.

The [R3] Financial Transaction Request message maps to the following A&L message:

- 0200 - Financial Transaction Request.

4.2.2.2 Message Definition

Message Element	LIS5 Bitmap Reference	Required	Notes / Conditions
Bit Map Secondary	001	C	Required for ICC transactions
Primary Account Number	002	M	
Processing Code	003	M	010000 for Financial Transaction
Amount, Transaction	004	M	
Amount, Cardholder Billing	006		Not required
Transmission Date and Time	007	M	
Conversion Rate, Cardholder Billing	010		Not required
Systems Trace Audit Number	011	M	
Time, Local Transaction	012	M	
Date, Local Transaction	013	M	
Date, Expiration	014	C	Required for manually key entered withdrawal transaction
Date, Settlement	015	M	Acquirer's settlement date
Point of Service Entry Mode	022	M	Please refer to section 4.1.2 for values
Application PAN Sequence	023	C	Required for ICC transactions, or if the card's issue number has been manually entered
Point of Service Condition Code	025	M	Please refer to section 4.1.2 for contents of the field
Amount, Transaction Fee	028		Not required - acquirer charge will not be used
Acquiring Institution Identification Code	032	M	
Forwarding Institution Identification Code	033		Not required.
Track 2 Data	035	C	Will not be present where card details manually entered.
Retrieval Reference Number	037	M	Please refer to section 4.1.2. for contents of the field
Card Acceptor Terminal Identification	041	M	
Card Acceptor Identification Code	042	M	
Card Acceptor Name / Location	043	M	
Currency Code, Transaction	049	M	
Currency Code, Cardholder Billing	051		Not required
PIN Data	052	C	Required if PIN used
Advice / Reversal Reason Code	060	C	Required for ICC and fallback transactions
Point of Service Data	061	M	Please refer to section 4.1.2 for values
Message Authentication Code	064		Not to be sent to A&L for this implementation.
Bit Map Tertiary	065	C	Required for ICC transactions
Authorisation Data	123	C	Sub Field 18 contains start date of card if it exists and card details are manually entered
Terminal Capability Profile	130	C	Required for ICC transactions
Terminal Verification Results	131	C	Required for ICC transactions
Unpredictable Number	132	C	Required for ICC transactions
Terminal Serial Number	133	O	Optional for ICC transaction
Issuer Application Data	134	C	Required for ICC transactions
Cryptogram (ARQC)	136	C	Required for ICC transactions
Application Transaction Counter	137	C	Required for ICC transactions
Application Interchange Profile	138	C	Required for ICC transactions
Cryptogram Transaction Type	144	C	Required for ICC transactions
Terminal Country Code	145	C	Req'd for ICC transactions – see section 4.1.2 for value



**NBX – A&L Application
Interface Specification**

Project: EMV – Banking and Retail

Doc Ref: NB/IFS/026

COMMERCIAL IN CONFIDENCE

Terminal Transaction Date	146	C	Required for ICC transactions
Cryptogram Amount	147	C	Required for ICC transactions
Cryptogram Currency Code	148	C	Required for ICC transactions
Message Authentication Code	192		Not required in this implementation

**NBX – A&L Application
Interface Specification**
Project: EMV – Banking and Retail

Doc Ref: NB/IFS/026

COMMERCIAL IN CONFIDENCE

4.2.3 [R3] - Financial Transaction Request - Deposit

4.2.3.1 Overview

This message is sent by the NBX to A&L. The message details a cash deposit request. Cheque deposits and mixed deposits, ie cash and cheques in one transaction, will not be supported on this interface.

The [R3] Financial Transaction Request message maps to the following A&L message:

- 0200 - Financial Transaction Request

4.2.3.2 Message Definition

Message Element	LIS5 Bitmap Reference	Required	Notes / Conditions
Bit Map Secondary	001	C	Required for ICC transactions
Primary Account Number	002	M	
Processing Code	003	M	210000 for cash deposit
Amount, Transaction	004	M	
Amount, Cardholder Billing	006		Not required
Transmission Date and Time	007	M	
Conversion Rate, Cardholder Billing	010		Not required
Systems Trace Audit Number	011	M	
Time, Local Transaction	012	M	
Date, Local Transaction	013	M	
Date, Expiration	014	C	Required for manually key entered deposit transaction
Date, Settlement	015	M	Acquirer's settlement date
Point of Service Entry Mode	022	M	Please refer to section 4.1.2 for values
Application PAN Sequence Number	023	C	Required for ICC transactions, or if the card's issue number has been manually entered
Point of Service Condition Code	025	M	Please refer to section 4.1.2 for contents of the field
Amount, Transaction Fee	028		Not required - acquirer charge will not be used
Acquiring Institution Identification Code	032	M	
Forwarding Institution Identification Code	033		Not required.
Track 2 Data	035	C	Will not be present where card details manually entered.
Retrieval Reference Number	037	M	Please refer to section 4.1.2 for contents of the field
Card Acceptor Terminal Identification	041	M	
Card Acceptor Identification Code	042	M	
Card Acceptor Name / Location	043	M	
Currency Code, Transaction	049	M	
Currency Code, Cardholder Billing	051		Not required
PIN Data	052		Not required for deposit transactions
Advice / Reversal Reason Code	060	C	Required for ICC transactions and fallback transactions
Point of Service Data	061	M	Please refer to section 4.1.2 for values
Message Authentication Code	064		Not to be sent to A&L for this implementation.
Bit Map Tertiary	065	C	Required for ICC transactions
Authorisation Data	123	C	Sub Field 18 contains start date of card if it exists and card details are manually entered
Terminal Capability Profile	130	C	Required for ICC transactions
Terminal Verification Results	131	C	Required for ICC transactions
Unpredictable Number	132	C	Required for ICC transactions
Terminal Serial Number	133	O	Optional for ICC transaction – to be inserted if available
Issuer Application Data	134	C	Required for ICC transactions
Cryptogram (ARQC)	136	C	Required for ICC transactions
Application Transaction Counter	137	C	Required for ICC transactions



**NBX – A&L Application
Interface Specification**

Project: EMV – Banking and Retail

Doc Ref: NB/IFS/026

COMMERCIAL IN CONFIDENCE

Application Interchange Profile	138	C	Required for ICC transactions
Cryptogram Transaction Type	144	C	Required for ICC transactions
Terminal Country Code	145	C	Req'd for ICC transactions – see section 4.1.2 for value
Terminal Transaction Date	146	C	Required for ICC transactions
Cryptogram Amount	147	C	Required for ICC transactions
Cryptogram Currency Code	148	C	Required for ICC transactions
Message Authentication Code	192		Not required in this implementation



4.2.4 [A1] - Balance Enquiry Response

4.2.4.1 Overview

This message is sent by A&L to the NBX. The message contains a balance enquiry response.

The [A1] Balance Enquiry Response message maps to the following A&L messages:

- 0110 - Balance Enquiry Response

4.2.4.2 Message Definition

Message Element	LIS5 Bitmap Reference	Required	Notes / Conditions
Bit Map Secondary	001	M	
Primary Account Number	002	M	Echoed from the request message
Processing Code	003	M	Echoed from the request message
Amount, Cardholder Billing	006		Not required
Transmission Date and Time	007	M	
Conversion Rate, Cardholder Billing	010		Not required
Systems Trace Audit Number	011	M	Echoed from the request message
Time, Local Transaction	012	M	Echoed from the request message
Date, Local Transaction	013	M	Echoed from the request message
Date, Settlement	015	M	A&L settlement date
Application PAN Sequence	023	C	Echoed from the request message if present
Acquiring Institution Identification Code	032	M	Echoed from the request message
Forwarding Institution Identification Code	033		Not required because not in request.
Retrieval Reference Number	037	M	Echoed from the request message
Response Code	039	M	
Card Acceptor Terminal Identifier	041	M	Echoed from the request message
Currency Code, Transaction	049	M	Echoed from the request message
Currency Code, Cardholder Billing	051		Not required
Additional Amounts	054	M	For a decline, the length of this field must be set to '000'
Bit Map Tertiary	065	C	Required for ICC transactions
Account Identification 1	102	M	NBX does not pass this field to the counter systems
Authorising Agent Institution Id Code	113	M	
Issuer Trace Id	126	M	
Message Authentication Code	128		Not to be sent to A&L for this implementation.
Application Transaction Counter	137	C	Required for ICC transactions
Issuer Authentication Data	139	C	Required for ICC transactions (omitted if cannot be generated)
Issuer Script	142	O	At Issuer's discretion
Message Authentication Code	192		Not required in this implementation



4.2.5 [A1] - Financial Transaction Request Response - Withdrawal

4.2.5.1 Overview

This message is sent by A&L to the NBX. The message contains a withdrawal request response .

The [A1] Financial Transaction Request Response message maps to the following A&L message:

- 0210 - Financial Transaction Request Response.

Note that A&L will never return a partial authorisation.

4.2.5.2 Message Definition

Message Element	LIS5 Bitmap Reference	Required	Notes / Conditions
Bit Map Secondary	001	M	
Primary Account Number	002	M	Echoed from the request message
Processing Code	003	M	Echoed from the request message
Amount, Transaction	004	M	Echoed from the request message
Amount, Cardholder Billing	006		Not required
Transmission Date and Time	007	M	
Conversion Rate, Cardholder Billing	010		Not required
Systems Trace Audit Number	011	M	Echoed from the request message
Time, Local Transaction	012	M	Echoed from the request message
Date, Local Transaction	013	M	Echoed from the request message
Date, Settlement	015	M	A&L settlement date
Application PAN Sequence	023	C	Echoed from the request message if present
Amount, Transaction Processing Fee	030	C	Field will not be returned by A&L in an A&L denied transaction.
Acquiring Institution Identification Code	032	M	Echoed from the request message
Forwarding Institution Identification Code	033		Not required because not in request.
Retrieval Reference Number	037	M	Echoed from the request message
Response Code	039	M	
Card Acceptor Terminal Identifier	041	M	Echoed from the request message
Currency Code, Transaction	049	M	Echoed from the request message
Currency Code, Cardholder Billing	051		Not required
Additional Amounts	054	C	Required if available from issuer
Bit Map Tertiary	065	C	Required for ICC transactions
Account Identification 1	102	M	NBX does not pass this field to the counter systems
Authorising Agent Institution Id Code	113	M	
Authorisation Response Data	121		Not required in NBX implementation
Issuer Trace Id	126	M	
Message Authentication Code	128		Not to be sent to A&L for this implementation.
Application Transaction Counter	137	C	Required for ICC transactions
Issuer Authentication Data	139	C	Required for ICC transactions (omitted if cannot be generated)
Issuer Script	142	O	At Issuer's discretion
Message Authentication Code	192		Not required in this implementation

**NBX – A&L Application
Interface Specification**

Project: EMV – Banking and Retail

Doc Ref: NB/IFS/026

COMMERCIAL IN CONFIDENCE

4.2.6 [A1] - Financial Transaction Request Response - Deposit

4.2.6.1 Overview

This message is sent by A&L to the NBX. The message contains a deposit request response.

The [A1] Financial Transaction Request Response message maps to the following A&L message:

- 0210 - Financial Transaction Request Response.

Note that A&L will never return a partial authorisation.

4.2.6.2 Message Definition

Message Element	Bitmap Reference	Required	Notes / Conditions
Bit Map Secondary	001	M	
Primary Account Number	002	M	Echoed from the request message
Processing Code	003	M	Echoed from the request message
Amount, Transaction	004	M	Echoed from the request message
Amount, Cardholder Billing	006		Not required
Transmission Date and Time	007	M	
Conversion Rate, Cardholder Billing	010		Not required
Systems Trace Audit Number	011	M	Echoed from the request message
Time, Local Transaction	012	M	Echoed from the request message
Date, Local Transaction	013	M	Echoed from the request message
Date, Settlement	015	M	A&L settlement date
Application PAN Sequence	023	C	Echoed from the request message if present
Amount, Transaction Processing Fee	030	C	Field will not be returned by A&L in a A&L denied transaction.
Acquiring Institution Identification Code	032	M	Echoed from the request message
Forwarding Institution Identification Code	033		Not required because not in request.
Retrieval Reference Number	037	M	Echoed from the request message
Response Code	039	M	
Card Acceptor Terminal Identifier	041	M	Echoed from the request message
Currency Code, Transaction	049	M	Echoed from the request message
Currency Code, Cardholder Billing	051		Not required
Additional Amounts	054	C	Required if available from issuer
Bit Map Tertiary	065	C	Required for ICC transactions
Account Identification 1	102	M	Not used by NBX
Authorising Agent Institution Id Code	113	M	
Authorisation Response Data	121		Not used in the NBX implementation
Issuer Trace Id	126	M	
Message Authentication Code	128		Not to be sent to A&L for this implementation.
Application Transaction Counter	137	C	Required for ICC transactions
Issuer Authentication Data	139	C	Required for ICC transactions (omitted if cannot be generated)
Issuer Script	142	O	At Issuer's discretion
Message Authentication Code	192		Not required in this implementation



4.2.7 [E1] - Reversal Request

4.2.7.1 Overview

This message is sent by the NBX to A&L when a financial transaction that has been processed by the issuer needs to be reversed.

The [E1] message maps to the following A&L messages:

- 0420 - Reversal Request
- 0421 - Reversal Repeat.

A Reversal Request [E1] can only be generated when the [A1] message to be reversed can be mapped against a [R3] request.

Reversal Requests may be sent up to a (configurable) period, initially set to 5 days, after the original transaction to which it refers.

Note that partial reversals are not supported over this interface.

4.2.7.2 Message Definition

Message Element	Bitmap Reference	Required	Notes / Conditions
Bit Map Secondary	001	M	
Primary Account Number	002	M	
Processing Code	003	M	Copied from the [A1]
Amount, Transaction	004	M	
Amount, Cardholder Billing	006		Not required
Transmission Date and Time	007	M	
Conversion Rate, Cardholder Billing	010		Not required
Systems Trace Audit Number	011	M	
Time, Local Transaction	012	M	
Date, Local Transaction	013	M	
Date, Expiration	014	C	Required if present on original transaction. Copied from original transaction
Date, Settlement	015	M	Copied from the [R3]
Merchant type	018		Not required
Acquiring Institution Country Code	019		Not required
Point of Service Entry Mode	022	M	
Application PAN Sequence Number	023	C	Required if present on original transaction
Point of Service Condition Code	025	M	
Amount, Transaction Fee	028		Not required - acquirer charge will not be used
Acquiring Institution Identification Code	032	M	
Forwarding Institution Identification Code	033		Not required
Track 2 Data	035	C	Required if present on original transaction
Retrieval Reference Number	037	M	
Authorisation Identification Response	038		Not required
Response Code	039	M	Copied from the [A1]
Card Acceptor Terminal Identifier	041	M	
Card Acceptor Identification Code	042	M	
Card Acceptor Name / Location	043	M	
Currency Code, Transaction	049	M	
Currency Code, Cardholder Billing	051		Not required
Advice / Reversal Reason Code	060	M	
Point of Service Data	061	M	
Bit Map Tertiary	065	C	Required for ICC transactions if any of the optional fields included
Original Data Elements	090	M	
Replacement Amounts	095		Not required

**NBX – A&L Application
Interface Specification**
Project: EMV – Banking and Retail

Doc Ref: NB/IFS/026

COMMERCIAL IN CONFIDENCE

Account Identification 1	102	M	Copied from original transaction. Space filled if no data is available
Authorisation Response Data	121		Not used in the NBX implementation
Authorisation Data	123	C	Required if present on original transaction
Issuer Trace Id	126	M	
Terminal Capability Profile	130	O	Optional for ICC transactions. Copied from original transaction
Terminal Verification Results	131	O	Optional for ICC transactions. This should contain the latest TVR which may be different to that in the original request. If the latest TVR is unavailable, the value in the original request should be used
Unpredictable Number	132	O	Optional for ICC transactions. Copied from original transaction
Terminal Serial Number	133	O	Optional for ICC transactions. Copied from original transaction
Issuer Application Data	134	O	Optional for ICC transactions. This should contain the latest IAD which may be different to that in the original request. If the latest IAD is unavailable, the value in the original request should be used
Cryptogram (ARQC)	136	O	Optional for ICC transactions. This should contain the ARQC from the 2 nd Gen. AC command or if unavailable, the ARQC from the 1 st Gen. AC command
Application Transaction Counter	137	O	Optional for ICC transactions. Copied from original transaction
Application Interchange Profile	138	O	Optional for ICC transactions. Copied from original transaction
Cryptogram Transaction Type	144	O	Optional for ICC transactions. Copied from original transaction
Terminal Country Code	145	O	Optional for ICC transactions. Copied from original transaction
Terminal Transaction Date	146	O	Optional for ICC transactions. Copied from original transaction
Cryptogram Amount	147	O	Optional for ICC transactions. Copied from original transaction
Cryptogram Currency Code	148	O	Optional for ICC transactions. Copied from original transaction
Message Authentication Code	192		Not required in this implementation

Note: NBX does not include any of the Optional fields.

**NBX – A&L Application
Interface Specification**
Project: EMV – Banking and Retail

Doc Ref: NB/IFS/026

COMMERCIAL IN CONFIDENCE

4.2.8 [E2] - Reversal Request Response

4.2.8.1 Overview

This message is sent by A&L to the NBX in response to a reversal request from the NBX.

The [E2] message maps to the A&L message 0430.

4.2.8.2 Message Definition

Message Element	LIS5 Bitmap Reference	Required	Notes / Conditions
Bit Map Secondary	001	M	
Processing Code	003	M	Echoed from the 042x message.
Amount, Transaction	004	M	Echoed from the 042x message.
Transmission Date and Time	007	M	Echoed from the 042x message.
Systems Trace Audit Number	011	M	Echoed from the 042x message.
Time, Local Transaction	012	M	Echoed from the 042x message.
Date, Local Transaction	013	M	Echoed from the 042x message.
Date, Settlement	015	M	Echoed from the 042x message.
Application PAN Sequence	023	C	Required if present on original transaction
Acquiring Institution Identification Code	032	M	Echoed from the 042x message.
Forwarding Institution Identification Code	033		Not required
Retrieval Reference Number	037	M	Echoed from the 042x message.
Response Code	039	M	
Currency Code, Transaction	049	M	Echoed from the 042x message.
Bit Map Tertiary	065	C	Required for ICC transactions
Original Data Elements	090	M	Echoed from the 042x message.
Replacement Amounts	095		Not required
Authorisation Response Data	121		Not required
Authorisation Data	123		Not required
Issuer Trace Id	126	M	Echoed from the 042x message.
Application Transaction Counter	137	C	Required for ICC transactions if present in reversal request. Copied from request
Cryptogram Transaction Type	144	O	Optional for ICC transactions. Copied from original transaction
Message Authentication Code	192		Not required in this implementation

**NBX – A&L Application
Interface Specification**

Project:

EMV – Banking and Retail

Doc Ref:

NB/IFS/026

COMMERCIAL IN CONFIDENCE

4.2.9 Administration Advice (0620)

4.2.9.1 Overview

Administration advice messages are sent to/from A&L in order to initiate investigation of a problem by either A&L or the NBX.

The Administration advice message maps to LIS5 message 0620.

4.2.9.2 Message Definition

Message Element	LIS5 Bitmap Reference	Required	Notes / Conditions
Bit Map Secondary	001	M	
Transmission Date and Time	007	M	
Systems Trace Audit Number	011	M	
Network Management Information Code	070	M	Set to be 900
Info Text	124	M	

**NBX – A&L Application
Interface Specification**

Project: EMV – Banking and Retail

Doc Ref: NB/IFS/026

COMMERCIAL IN CONFIDENCE

4.2.10 Network Management Messages (0800 / 0810)

The following Network Management Messages will be exchanged between A&L and the NBX:

- 0800 - Network Management Request Message
- 0810 - Network Management Response Message

They are used for the following purposes (followed by associated Network Management Information Code) and the designation of NBX/A&L denotes which party may initiate the particular message:

Message Type	NMIC	Initiator
Log On	061	A&L
Log On	071	NBX
Log Off	062	A&L
Log Off	072	NBX
Key Change	161	A&L
Key Change Request	181	NBX
Online Key Verification	199	A&L (Note – not used by A&L)
End of Day (Cutover)	271	NBX
Handshake	361	A&L
Handshake	371	NBX

The usage, sequence and inter-relation between these and other messages is defined in the body of the document "LINK Switch Service Interchange Standard (LIS5)" (Ref. [4] and in Appendix C1 of the "LIS5 Security Standard" section of that document under Network Management Option 2, (Ref. [8]).

4.2.10.1 Network Management Request (0800)

Message Element	LIS5 Bitmap Reference	Required	Notes / Conditions
Bit Map Secondary	001	M	
Transmission Date and Time	007	M	
Systems Trace Audit Number	011	M	Set for this transaction – a new STAN is used when a 0800 message is repeated
Network Management Information Code	070	M	Values will depend on message purpose, as described above.
Message Security Code	096	C	Required for key change, key verification, logon and logoff
Network Management Information	125	C	Required for key change and key verification

Note: The 0800 End of Day message is sent to A&L based on a timed event at 20:00. An 0810 Message response is mandated with a zero response code. This message is to be repeated for a limited number of times and to a timed interval to be specified in configurable parameters. When the repeat number is exceeded then operational procedures are to be followed.

4.2.10.2 Network Management Request Response (0810)

Message Element	LIS5 Bitmap Reference	Required	Notes / Conditions
Bit Map Secondary	001	M	
Transmission Date and Time	007	M	
Systems Trace Audit Number	011	M	Echoed from the 0800
Response Code	039	M	
Network Management Information Code	070	M	This is echoed from the 0800 received message.



**NBX – A&L Application
Interface Specification**

Project: EMV – Banking and Retail

Doc Ref: NB/IFS/026

COMMERCIAL IN CONFIDENCE

4.1.11 Reconciliation and Settlement

4.1.1.1 Overview

A Reconciliation Report is sent to A&L each day, providing a record per A&L transaction for that Settlement day. The file transfer mechanism and conditions of transfer are described in the NBX – A&L Technical Interface Specification, (Ref. [1]), and the Reconciliation File Format (Ref. [3]).



5 Transfer Structure

5.1 Transfer Grouping

The following figure shows the end to end message sequences, using the RACE (Request / Authorise / Confirm / Exception) model, for all application messages between the NBX and A&L.

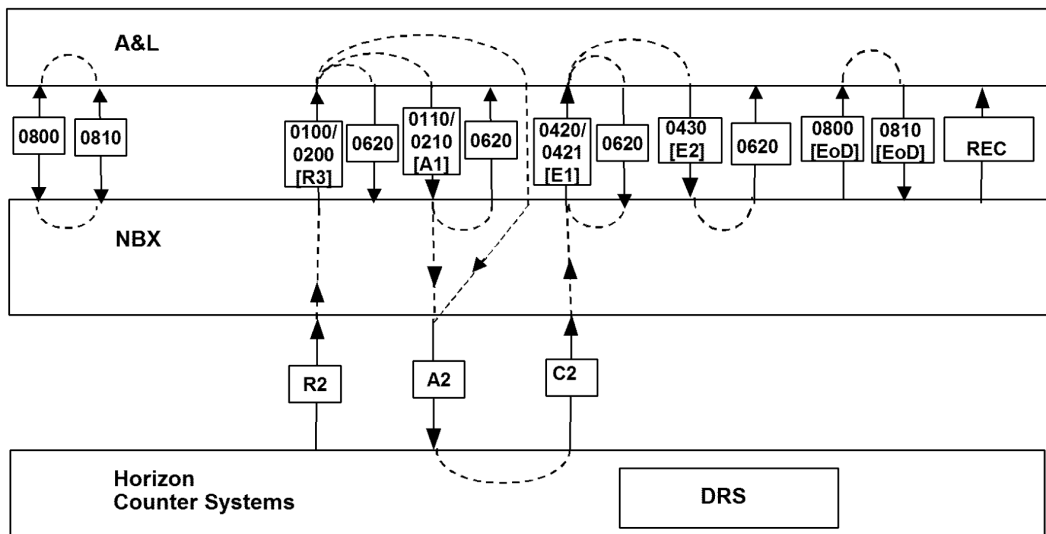

Figure 1 – A&L Message Flows in the Network Banking Environment

An 0620 message may be issued by the NBX in response to all messages from A&L (for simplicity, only some such flows are shown on the diagram).

Reversals (0420/0421 messages) are not sent from NBX to A&L unless and until an approved response (0210 message) has been received from A&L. Repeat reversals (0421) are only sent in the event that the prior 0420 (or 0421) reversal messages have not had a response processed at the NBX.



**NBX – A&L Application
Interface Specification**

Project: EMV – Banking and Retail

Doc Ref: NB/IFS/026

COMMERCIAL IN CONFIDENCE

NBX will use the new settlement date without waiting for a response from A&L. A&L may receive authorisation requests with the previous settlement date after it has received the End of Day Cutover, because of parallelism.

The interface should be resilient to the transfer of duplicate messages; in practice, however, this should only happen after failure and recovery of either end of the interface.

A&L will not validate transmission date and time in messages against the date and time that messages are received.

The interface details are also described in the NBX – A&L Technical Interface Specification (Ref. [1])

5.2 Transfer Structure

The messages defined in this AIS will be exchanged in accordance with Section 3 of the LINK Switch Service Interchange Standard (LIS5), (Ref. [4]), which describes the use of Message Type Identifier, Bit Map and Data Elements in the message structure. Note that the messages exchanged over this interface use the third bit map for the ICC data elements.

Messages for one transaction may be interleaved with messages for any other transaction.

5.3 Record Structure

The record structure for the messages defined in this AIS is as described in the LIS5 Interchange Standard, (Ref. [4]). The details are not repeated here.

The record structure for the Reconciliation File passed over this interface is described in NBX-A&L Reconciliation File Format (Ref. [3]). The details are not repeated here.

5.4 Sequences

Figure 1 above (see Section 5.1) shows the end to end message sequences of all the messages supported by this AIS, from the PO Outlet to the issuing financial institution.

Further detail relating specifically to the NBX – A&L connection can be found in the NBX – A&L Technical Interface Specification (Ref. [1]). The interface must be resilient to the disconnection or loss of any part of the total network banking environment for short or extended periods.

5.5 Data Volumes

Data rates and volumes over this interface are addressed through the document NB Volume Model Comparisons [Ref. [5]].

5.6 Data Authentication

For this implementation, Message Authentication Codes (MACs) will not be included in the messages sent between the NBX and A&L.

5.7 Data Dictionary

The Data Elements used on this interface are defined and described within section 4.1.2



**NBX – A&L Application
Interface Specification**

Project:

EMV – Banking and Retail

Doc Ref:

NB/IFS/026

COMMERCIAL IN CONFIDENCE



6 Security of Transmitted Data

The security standards for the A&L-NBX interface are described in the NBX – A&L Technical Interface Specification (Ref. [1]).

6.1 Protected Data

PIN blocks that pass across the interface from NBX to A&L are encrypted under an Acquirer Working Key (AWK). This key is used in the A&L – NBX shared security zone. PIN Block encryption is translated from internal keys to protection under this shared key using a hardware encryption module. The PIN blocks are never rendered in clear outside the hardware module.

Acquirer Working Keys are exchanged electronically under a Acquirer Zone Master Key (AZMK) shared between Fujitsu Services and A&L. The AZMK is generated and owned by Fujitsu Services. The AWK is owned and generated by A&L.

6.2 Encryption and Decryption Methods

PIN Block and Acquirer Working Key transmission is protected by Triple DES double length keys, 112bit plus key check data.

6.3 Session Establishment

Session Establishment can be initiated by A&L or NBX. Initial Logon messages exchanges are followed by transmission by A&L to NBX of a new AWK (with a key check value) protected by encryption under the shared current AZMK.

NBX verifies the key and acknowledges it to A&L. All PIN Block data is protected by this AWK until the session ends or the AWK is renewed.

6.4 Key Management

Key ownership is described in the NBX – A&L Technical Interface Specification (Ref. [1]). A&L - NBX Acquirer Zone Management Keys are managed by the Horizon Key Management Application (KMA) with manual processes.

According to local manual processes the NBX staff will:

- Generate three new AZMK components
- Transfer the AZMK components onto secure stationery
- Key components will contain
 - A key identifier (visible)
 - A key generation date (visible)
 - A component number (visible)
 - 32 hex characters in eight groups of four characters – component plus check data (hidden)
- Provide a Key Check value
- Load the keys into the Horizon KMA

**NBX – A&L Application
Interface Specification**

Project: EMV – Banking and Retail

Doc Ref:

COMMERCIAL IN CONFIDENCE

The Horizon KMA:

- Activates keys for use by Horizon Agents, which manage the TCP/IP connections to A&L.

Key component documents must be stored and transported separately and securely (see the Operational Level Agreement (Ref. [2])). .

The A&L – NBX AZMK is renewed every six months by this manual procedure. The AZMK, having been produced as described above, is securely transported, manually, to A&L. This is followed by the manual promotion of the AZMK, where the Next AZMK becomes the Current AZMK. It is recommended that after promotion of the keys, an A&L Operator issue a command to drive an AWK Key change request sequence, in order to test that the verified AZMK has been promoted by both parties.

A&L requires more than one Processor Interface (PI) to support the transaction throughput for the NBX. For this configuration each PI will be configured to support one TCP/IP socket connection. A logical session will be initiated by a logon, and data for that session will flow over the socket connection belonging to that PI (see Ref. [6] for further details). Each PI generates an A&L-NBX Acquirer Working Key (AWK) which it sends to NBX for validation. This AWK, if validated by the NBX, is used between NBX and the PI that generated it. Logical sessions for a different PI will use the AWK generated by that PI. All A&L PIs will protect their AWK in transit to NBX by encryption using the same AZMK, during its six months of currency.

The AWKs are changed under the following conditions.

- Every 24 hours where the session remains active (an AWK may be changed at a set (configurable) clock time and will remain valid until it is changed)
- At session initiation by either party
- On receipt by A&L of a 6th consecutive invalid PIN block on a session (note that Fujitsu Services is not required to track invalid PIN blocks)
- When an A&L operator requests a key change (NBX can request a key change in theory but in practice NBX will force a Log off / Log on).

Load balancing between the PIs will be performed by the NBX ensuring that the appropriate AWK for the PI is used for PIN block translation.

It has been agreed that:

- A&L support the use of the current and previous AWK
- NBX can start using new AWK received from A&L for encryption as soon as it is received
- NBX and A&L must be able to carry on normal business, including ability to accept new AWK keys, while AZMK is being changed
- There may be a short outage at the FI (typically up to 90 seconds) while the manual process for changing the AZMK is under way.



7 Operational Procedures

7.1 Processing Cycles

This interface relates to online message exchange to support real time financial transactions, and to the daily transmission from NBX of the Reconciliation and Settlement file.

Timed out ("Stale") messages are logged and discarded before transmission or on receipt, as appropriate. Please refer to section 7.4 for details of which message types can be discarded (i.e. non "Must deliver" messages).

"Must deliver" messages are retransmitted at parameter intervals until delivery is successful, as described in the NBX Operational Procedures Manual, (Ref. [2]).

In this section a transaction, which is referred to as discarded, must be logged after receipt, prior to being discarded.

7.2 Transfer Initiation

All transfers defined in this AIS are automatic.

7.3 Security Procedures

Manual Procedures are required to support the above key management protocol, as described in Section 6. They will need to be agreed between the A&L operator and the NBX operator for inclusion / reference in the Operational Level Agreement (OLA) between them.

Two key components shall be sent to nominated key component holders in Alliance and Leicester, a third will be carried to A&L by an NBX key component holder who will be responsible for entering it into the key management system.

The A&L and NBX key management system must not require that the financial transaction processing system be taken off line to install AZMK components and to activate the new AZMK. Access to the Key Management System, its security hardware and associated commands must be restricted to the key manager.

7.4 Fallback Procedures

Fallback procedures are described in the NBX – A&L Technical Interface Specification, (Ref. [1]).

Each system is responsible for its own recovery after failure. Restoration of the interface and the disposal of stale messages (other than "must deliver" messages) is expected to be automatic. 0100 [R3], 0200 [R3], 0110 [A1], 0210 [A1], 0620 and 0800 Network Management messages awaiting transmission at the time of failure can safely be discarded, as the integrity of the transaction is protected by timeouts.

Failures which impact non-transient (or "must-deliver") messages, require recovery actions to ensure their eventual delivery. In the case of messages from A&L to the NBX, A&L will retain such messages and they will be resent once a connection is found to be re-established (by means of periodic handshakes). In the case of messages from the NBX to A&L, the NBX will continue to retain messages and A&L will resume the fetching of such messages as soon as connections are re-established.

**NBX – A&L Application
Interface Specification****Project:** EMV – Banking and Retail**Doc Ref:****COMMERCIAL IN CONFIDENCE**

The only messages categorised as “must deliver” are Network Management (0800) and Reversal Request (0420/0421) messages - see Section 6 of the LINK Switch Service Interchange Standard (LIS5), (Ref. [4]). Sign On, Sign Off, Key Change and Key Change Request 0800 messages are “must deliver” but do not have to survive across processes when moving from active to standby sites.

Handshake 0800 messages are sent every few minutes anyway (which is sufficient).

End of Day 0800 and Reversal Request 0420/0421 messages are “must deliver” messages and do have to survive when moving from active to standby sites.

Please note that there may be manual operational re-alignment required should messages that were thought to have been delivered turn out to have been lost.

7.5 Downgrade Transactions

A ‘Downgrade’ transaction is one where an IC Card has been used at an ICC enabled terminal, but the card issuer has advised, via POL reference data (dependent upon IIN), that the card must not be processed as ICC. The on-line message will be formatted as a standard magnetic stripe transaction.

Nothing, apart from the Track 2 Service Code in the on-line LIS5 Message sent to A&L, will indicate that an IC Card was used.

Note that in the case of a Downgrade transaction, data must not be used from the IC, but that normal procedures must be followed as for magnetic stripe cards.

7.6 Control

The interface must be resilient to duplicate messages, which may occur after recovery of any element in the system, but are not otherwise expected to occur.

Lost or discarded messages are handled by timeout processing at every stage of the “RA” message sequence, to ensure that incomplete transactions are declined if unauthorised or reversed if authorised.

The NBX will log events affecting this interface (e.g. response indicating receipt by A&L of an invalid PIN block) to an Event Log. These events will be managed by Tivoli for escalation to the relevant Help Desk, as appropriate to the code associated with the event.



**NBX – A&L Application
Interface Specification**

Project:

EMV – Banking and Retail

Doc Ref:

COMMERCIAL IN CONFIDENCE

8 Appendix A

The document NBX-A&L Mapping (Ref. [6]) contains the complete mapping from Horizon to/from the NBX to/from A&L .

END OF DOCUMENT